

IN THE UNITED STATES PATENT AND TRADEMARK OFFICE

In re application of:	Noel C. Cobb et al.	Group Art Unit:	3724
Serial No.:	10/822,240	Examiner:	Jason D. Prone
Filed:	April 9, 2004		
For:	UTILITY KNIFE FOR GLAZIERS		
Docket No.:	0075-1		

March 14, 2008
Bedminster, NJ 07921

Board of Patent Appeals and Interferences
United States Patent and Trademark Office
Commissioner for Patents
P.O. Box 1450
Alexandria, VA 22313-1450

APPEAL BRIEF

This Brief is in furtherance of the Notice of Appeal entered February 15, 2008 in the above-identified application.

CERTIFICATE OF MAILING BY FIRST CLASS MAIL

I hereby certify under 37 CFR §1.8(a) that this correspondence is being deposited with the United States Postal Service as first class mail with sufficient postage on the date indicated below and is addressed to the Commissioner for Patents, P.O. Box 1450, Alexandria, VA 22313-1450

03/18/2008 HDESTA1 00000024 10822240
02 FC:2402 255.00 OP

March 14, 2007
Date of Deposit

Signature

Ernest D. Buff
Typed or Printed Name of Person Signing Certificate

TABLE OF CONTENTS

I.	Real Party in Interest	3
II.	Related Appeals and Interferences	4
III.	Status of Claims	5
IV.	Status of Amendments	6
V.	Summary of Claimed Subject Matter	7
	(A) Independent claim 2	7
	(B) Means/Step Plus Function Claims	12
VI.	Grounds of Rejection To Be Reviewed On Appeal	13
VII.	Arguments	14
	(A) Claims 2, 4, 5, 7, and 10-12.....	14
	1. Claim 2, 4, 5, 7, and 10-12.....	15
	2. Conclusion	16
	(B) Claim 2	17
	1. Claim 2	20
	2. Conclusion	26
VIII.	Conclusion	27
IX.	Claims Appendix.....	28
X.	Evidence Appendix.....	30
XI.	Related Proceedings Appendix.....	31

Applicant : Noel C. Cobb et al.
Serial No. : 10/822,240
Filed : April 9, 2004
Page : 3

Attorney Docket No.: 0075-1

(I) Real Party in Interest

The real parties in interest are Noel C. Cobb and Edward Bilenski, the co-inventors of the present invention.

Applicant : Noel C. Cobb et al.
Serial No. : 10/822,240
Filed : April 9, 2004
Page : 4

Attorney Docket No.: 0075-1

(II) Related Appeals and Interferences

There is an existing, or at the least a soon-to-be existing, pending appeal in related Application No. 11/352,728, which may directly affect or be directly affected by, or have a bearing on, the Board's decision in the present pending appeal.

(III) Status of Claims

The claims on appeal are claims 2, 4, 5, 7, and 10-12, which were finally rejected in the Office Action dated January 14, 2008. A copy of these claims is set forth in Section IX – Claims Appendix.

Originally-filed claims 1, 3, 6, and 8-9 have been cancelled during prosecution.

Claims 2, 4, 5, 7, and 10-12 stand finally and provisionally rejected under 35 U.S.C. §101 as claiming the same invention as that of claims 2, 4, 5, 7, and 10-12 of copending Application No. 11/352,728.

Claims 2, 4, 5, 7, and 10-12 stand finally rejected under 35 U.S.C. §103(a) as being unpatentable over US Patent 6,848,185 to Tebo in view of US Patent 4,109,380 to Anderson and further in view of US Patent 6,321,455 to Burchell.

Applicant : Noel C. Cobb et al.
Serial No. : 10/822,240
Filed : April 9, 2004
Page : 6

Attorney Docket No.: 0075-1

(IV) Status of Amendments

The claim listing set forth in Section IX reflects the pending claims, i.e. claims 2, 4, 5, 7, and 10-12, which were presented by way of applicants' amendment under 37 CFR §1.111 that was submitted on November 7, 2007. Entry of these claims was confirmed by the Office Action dated January 14, 2008, wherein claims 2, 4, 5, 7, and 10-12 were finally rejected.

(V) Summary of Claimed Subject Matter

Independent claim 2 is pending in the present application, along with claims 4, 5, 7, and 10-12 dependent on claim 2.

A. Independent claim 2.

Independent claim 2 is directed to a utility knife for glaziers and SHEET ROCK (TM) dry wall users. The device consists essentially of: (i) a reversible, detachable blade; (ii) a substantially V-shaped handle for supporting the blade; (iii) channel means for containing and support the blade; (iv) locating means for capturing the blade; (v) clamping means for supporting the knife blade; and (vi) a cavity for holding extra knife blade elements.

One possible and representative embodiment of the utility knife delineated by independent claim 2 is depicted by Figs. 1-4 of the instant application, which respectively show various views of utility knife 10 of the invention. For convenience, these figures are reproduced below.

Fig. 1

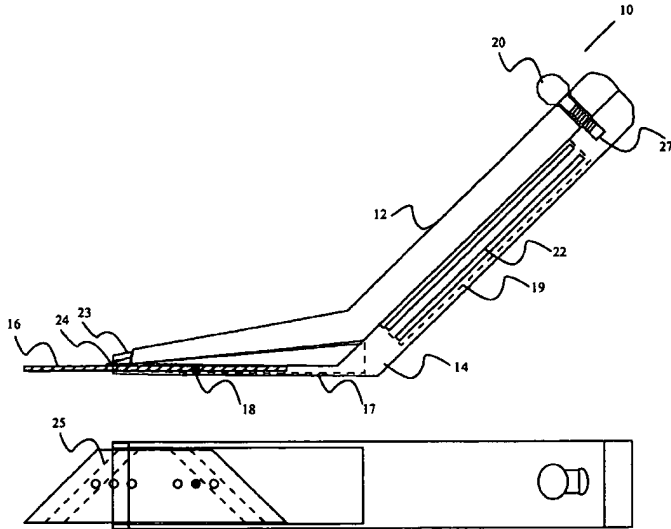

Fig. 2

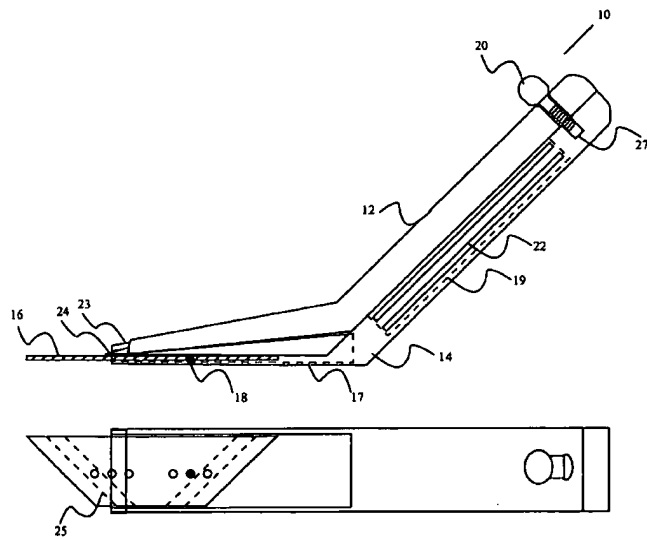

Fig. 3

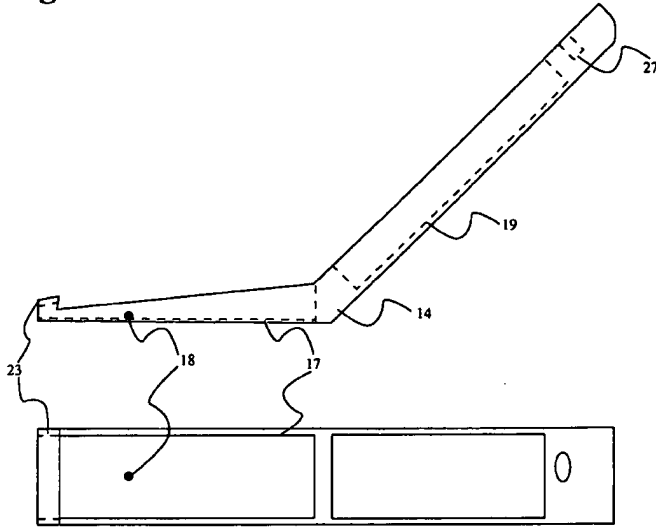
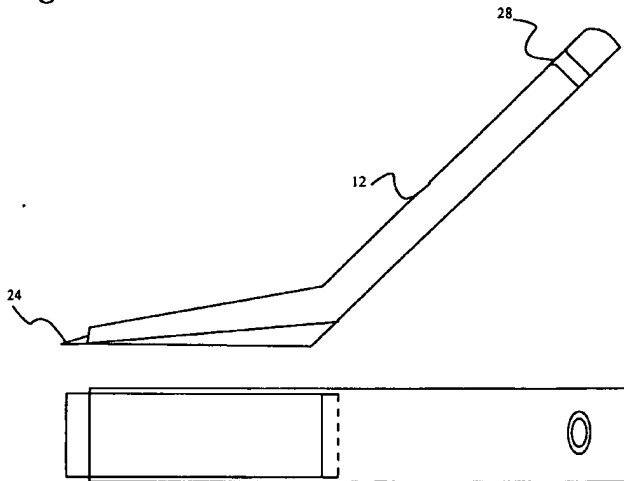

Fig. 4



The subject matter of claim 2 and corresponding references to teaching of at least one possible and exemplary implementation provided by the specification and the drawing figures are set forth in the following claim chart.¹

Elements of Claim 2	Teaching of the Original Specification and Drawing Figures
A utility knife for glaziers and SHEET ROCK (TM) dry wall users, comprising,	Page 13, lines 21-23.
a. a reversible, detachable blade (25) having a flat surface that defines a two-dimensional plane in space,	Page 13, line 24; Figs. 1-2, # 25.
said blade (25) having a sharp edge (29) and a plurality of anchoring holes (30);	Page 13, line 24; Figs. 1-2, #25; Fig. 5, #30.
b. a substantially V-shaped handle for supporting the blade (25),	Page 14, lines 16-19; Figs. 1-4, #10.
said handle comprising a substantially V-shaped first member (12) and a substantially V-shaped second member (14), wherein said first member (12) is removably attached to said second member (14) in order to create said substantially V-shaped handle,	Page 13, lines 21-24; Page 17, lines 4-7; Figs. 1-4, # 12-14.
wherein one leg of the V-shape is a gripping portion and the other leg of the V-shape is a blade supporting portion,	Page 13, lines 21-24; Page 17, lines 4-7; Figs. 1-4.
and said gripping portion is angulated with respect to said blade (25) such that said gripping portion is angulated away from and out of said two-dimensional plane;	Page 13, lines 21-24; Page 17, lines 4-7; Page 17, lines 9-12; Figs. 1-4.

¹ Parenthesized numerals have been interpolated in the quotation of claim language in the left column. These numerals refer to reference numerals used in the Figures of the instant application.

Elements of Claim 2	Teaching of the Original Specification and Drawing Figures
c. channel means (17) disposed within said blade supporting portion of said handle for containing and supporting said blade (25);	Page 14, lines 5-7; Page 18, lines 15-19; Figs. 1-3, #17.
d. locating means (18) disposed within said channel means (17) for capturing said blade (25);	Page 14, lines 1-2; Page 18, lines 2-6; Figs. 1-3, #18.
e. clamping means (20, 27) for clamping said first (12) and second (14) members and supporting said knife blade (25); and	Page 14, lines 2-5; Page 17, line 23 to Page 18, line 2; Figs. 1-3, #20, 27.
f. a cavity (19) for holding extra knife blade elements (22);	Page 14, lines 11-12; Page 18, lines 8-9; Figs. 1-3, #19, 22.
wherein a user may expose a fresh edge of said blade by either replacing said blade with a new blade from said cavity or by rotating said blade by 180 degrees to change handedness of said utility knife.	Page 14, lines 12-15; Page 17, lines 2-4.

B. Means/Step-Plus-Function Claims.

Claim 2 employs means-plus-function language of the type contemplated by 35 USC 112, sixth paragraph. More specifically, subsections (c) “clamping means”, (d) “locating means”, and (e) “clamping means” of claim 2 are hereby identified as employing means-plus-function language of the type contemplated by 35 USC 112, sixth paragraph. The structure described in the specification as corresponding to each claimed function has been properly set forth with reference to the specification by page and line number, and to the drawing, if any, by reference characters at section (V)(A) hereinabove.

Applicant : Noel C. Cobb et al.
Serial No. : 10/822,240
Filed : April 9, 2004
Page : 13

Attorney Docket No.: 0075-1

(VI) Grounds of Rejection To Be Reviewed on Appeal

(A) Whether claims 2, 4, 5, 7, and 10-12 should be rejected under 35 U.S.C. §101 as claiming the same invention as that of claims 2, 4, 5, 7, and 10-12 of copending Application No. 11/352,728;

(B) Whether claim 2 should be rejected under 35 U.S.C. §103(a) as being unpatentable over US Patent 6,848,185 to Tebo in view of US Patent 4,109,380 to Anderson and further in view of US Patent 6,321,455 to Burchell.

(VII) Arguments

A. The utility knife of claims 2, 4, 5, 7, and 10-12 meets the conditions for patentability, and should not be subject to rejection under 35 U.S.C. §101 as claiming the same invention as that of claims 2, 4, 5, 7, and 10-12 of copending Application No. 11/352,728.

The Examiner has provisionally rejected claims 2, 4, 5, 7, and 10-12 under 35 U.S.C. §101 as claiming the same invention as that of claims 2, 4, 5, 7, and 10-12 of copending Application No. 11/352,728 on the following basis:

Claims 2, 4, 5, 7, and 10-12 are provisionally rejected under 35 U.S.C. 101 as claiming the same invention as that of claims 2, 4, 5, 7, and 10-12 of copending Application No. 11/352,728. This is a provisional double patenting rejection since the conflicting claims have not in fact been patented. (Office Action of January 14, 2008, page 2.)

For the convenience of the Board, present claim 2 of copending Application No. 11/352,728, is reproduced below.

2. A utility knife for carpet installers, roofers, glaziers and SHEET ROCK (TM) dry wall workers, comprising,

- a. a reversible, detachable double-edged blade having a flat surface that defines a two-dimensional plane in space, said blade having a plurality of sharp edges and two anchoring holes;
- b. a substantially V-shaped handle for supporting the blade, said handle comprising a substantially V-shaped first member and a substantially V-shaped second member,

wherein said first member is removably attached to said second member in order to create said substantially V-shaped handle, wherein one leg of the V-shape is a gripping portion and the other leg of the V-shape is a blade supporting portion, and said gripping portion is angulated with respect to said blade such that said gripping portion is angulated away from and out of said two-dimensional plane;

- c. channel means disposed within said blade supporting portion for containing and supporting said double-edged blade;
- d. locating means disposed within said channel means for capturing said double-edged blade;
- e. clamping means for clamping said first and second members and supporting said double-edged blade; and
- f. a cavity for holding extra knife blade elements;

whereby a worker may expose a fresh edge of said blade by either replacing said blade with a new blade from said cavity or by rotating said blade by 180 degrees or turning said blade upside down;

and whereby said utility knife can be used for left-handed or right-handed operation.

1. Independent claim 2 (and claims 4, 5, 7, and 10-12 dependent thereon) meets the conditions for patentability because these claims recite an altogether different embodiment than the embodiment defined by present claim 2 of copending Application No. 11/352,728.

MPEP 804(II)(A) states that a reliable test for double patenting under 35 U.S.C. 101 is whether a claim in the application could be literally infringed without literally infringing a corresponding claim in the patent. In re Vogel, 422 F.2d 438, 164 USPQ 619 (CCPA 1970). Applicant submits that independent claim 2 of the present application does not require the blade of the knife to be “double-edged”. Therefore, independent claim 2 could be literally infringed without literally infringing the corresponding claim in copending Application No. 11/352,728, that is by having a blade that is “single-edged”, rather than “double-edged”.

Therefore, it is submitted that (1) a knife with a “single-edged” blade is a different embodiment than (2) a knife with a “double-edged” blade. Because the present claims represent a broader embodiment when compared with the claims in copending Application No. 11/352,728, it is submitted that a statutory double patenting rejection is not appropriate. Further, it is submitted that the feature of “a double-edged knife blade” is essential to the copending Application No. 11/352,728, *see* MPEP 806.03.

Simply put, present claims 2, 4, 5, 7, and 10-12 do not represent the “same invention” as the claims in copending Application No. 11/352,728, since they do not include identical subject matter. *See* MPEP 804(II)(A). Appellants submit that at most there exists a nonstatutory obviousness-type double patenting situation between present claims 2, 4, 5, 7, and 10-12 and copending Application No. 11/352,728. Therefore, appellants submit their willingness to submit a Terminal Disclaimer, at the request of the Examiner or the Board.

2. Conclusion.

In view of the foregoing remarks, it is submitted that present claims 2, 4, 5, 7, and 10-12 meet the conditions for patentability. Accordingly, reversal of the

rejection of claims 2, 4, 5, 7, and 10-12 under 35 USC §101 as claiming the same invention as that of claims 2, 4, 5, 7, and 9-12 of copending Application No. 11/352,728 is respectfully requested.

B. The utility knife of claim 2 meets the conditions for patentability, and should not be subject to rejection under 35 U.S.C. §103(a) as being unpatentable over US Patent 6,848,185 to Tebo in view of US Patent 4,109,380 to Anderson and further in view of US Patent 6,321,455 to Burchell.

The Examiner has rejected claim 2 under 35 U.S.C. §103(a) as being unpatentable over US Patent 6,848,185 to Tebo in view of US Patent 4,109,380 to Anderson and further in view of US Patent 6,321,455 to Burchell on the following basis:

Claims 2, 4, 5, 7, and 10-12 are rejected under 35 U.S.C. 103(a) as being unpatentable over Tebo (6,848,185) in view of Anderson (4,109,380) further in view of Burchell (6,321,455). (Office Action of January 14, 2008, page 2.)

Tebo discloses a utility knife including: a body defining an interior cavity, and a blade carriage slidably disposed within the cavity. The blade carriage is configured for removably receiving at least one blade, and is at least partially slidably removable from the cavity, thereby allowing facile replacement of the blade. In one embodiment, the carriage may receive first and second blades, each of which is extensible from an associated end of the body.

A utility knife blade including dual cutting edges and cutting points is also provided. The utility knife is readily visualized in the depiction of Figs. 1-2 of Tebo, which are reproduced below for the convenience of the Board.

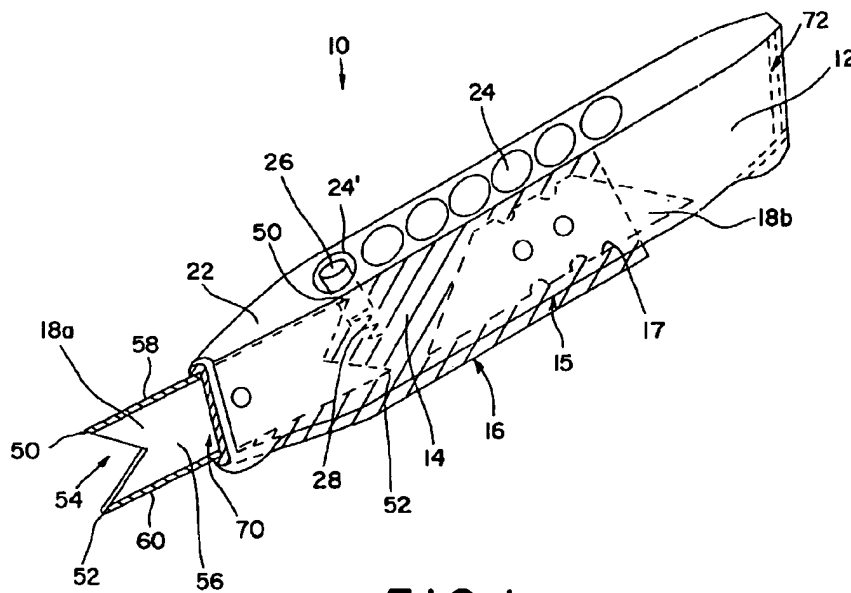

FIG. 1

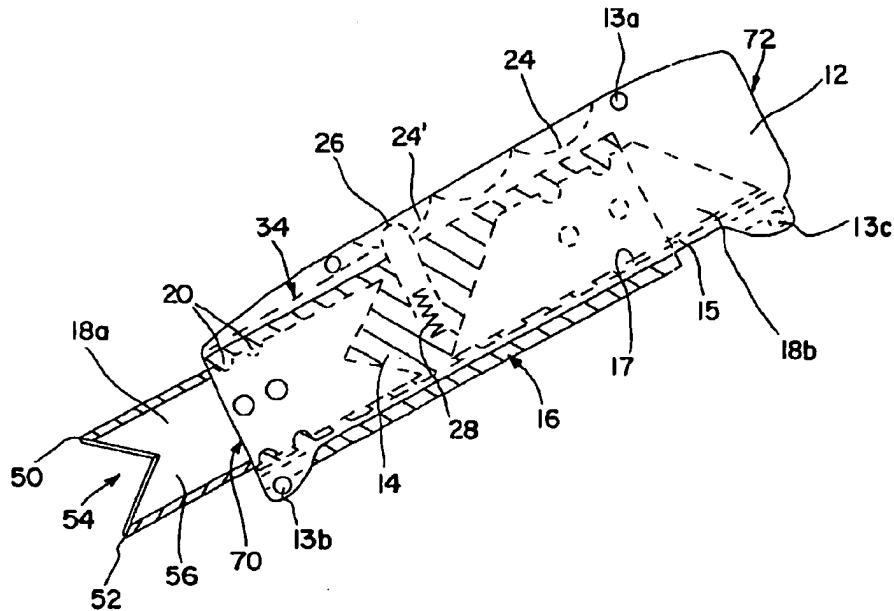

FIG. 2

(Tebo, US Patent 6,848,185)

With reference to Figs. 1-2, there is seen specially configured blade carriage 14, which is slidably moveable along the longitudinal axis within the cavity 12 between a first position wherein the first blade 18a extends from the first opening 70 and second position wherein the second blade 18b extends from the second opening 72.

1. Independent claim 2 meets the conditions for patentability because Tebo in view of Anderson and further in view of Burchell does not disclose or suggest the utility knife of claim 2.

With respect to claim 2, the Examiner provides the following basis for his rejection:

In regards to claim 2, Tebo discloses the invention including a reversible, detachable blade having a flat surface that defines a two-dimensional plane and having a plurality of sharp edges and two anchoring holes (56 in Fig. 2), a handle for supporting the blade (12), a first member and a second member (Fig. 2), a channel means disposed within the handle for containing and supporting the blade (Fig. 2), a locating means disposed within the channel for capturing the blade (2), a cavity for holding extra knife blades (15).

However, with regards to claims 1, 2, 4, 5, 10, and 11, Tebo fails to disclose the first and second members are substantially V-shaped and together create a substantially V-shaped handle, one leg of the V is a gripping portion and the other leg is a blade supporting portion, the gripping portion is angulated away from the blade, a clamping means for clamping the first and second members and supporting the blade...

Anderson teaches that it is old and well known in the art of utility blades to incorporate first and second members are substantially V-shaped and together create a substantially V-shaped handle (900 and 901), one leg of the V is a gripping portion (side opposite 908) and the other leg is a blade supporting portion (908), the gripping portion is angulated with away from the blade (Fig. 9), a clamping means for clamping the first and second members and supporting the blade (902)... Therefore, it would have been obvious to one of ordinary skill in the art, at the time of the invention, to have provided Tebo with the handle, as taught by Anderson because all claimed elements were known in the prior art and one skilled in the art could have combined the elements as claimed by known methods with no change in their respective function and the combination would have yielded predictable results.

Anderson teaches that V-shaped handles come in many variations. However, with regards to claim 2, Tebo in view of Anderson fail to disclose the gripping portion is angulated out of the two-dimensional plane.

Burchell teaches it is old and well known in the art of V-shaped knives to incorporate a gripping portion that angulated out of the two-dimensional plane (Fig. 2). Therefore, it would have been obvious to one of ordinary skill in the art, at the time of the invention, to have provided Tebo in view of Anderson with the handle, as taught by Burchell because all claimed elements were known in the

prior art and one skilled in the art could have combined the elements as claimed by known methods with no change in their respective function and the combination would have yielded predictable results. (Office Action of January 14, 2008, pages 2-4.)

Appellant respectfully submits that the foregoing statement of rejection does not establish *prima facie* obviousness.

a. Independent claim 2 meets the conditions for patentability because Tebo in view of Anderson and further in view of Burchell does not disclose or suggest every feature of the utility knife of claim 2.

There is no disclosure or suggestion in Tebo in view of Anderson and further in view of Burchell of the configuration or functionality of the utility knife of claim 2. In particular, the first and second V-shaped members of Anderson are not equivalent to the V-shaped members required by present claim 2. The V-shaped members of present claim 2 are configured such that the gripping portion of the utility knife is angulated with respect to the blade such that the gripping portion is angulated away from and out of the two-dimensional plane defined by the knife blade. Put simply, Anderson's V-shaped members are angled in the same plane defined by the knife blade. Therefore, the Examiner's reliance on the teachings of Anderson is misplaced. Present claim 2 requires a substantially V-shaped first member and a substantially V-shaped second member to combine to form a substantially V-shaped handle, wherein one leg of the V-shape is a gripping portion and the other leg of the V-shape is a blade supporting portion, and the gripping portion is angulated with respect

to the blade such that the gripping portion is angulated away from and out of the two-dimensional plane defined by the knife blade. Therefore, Tebo in view of Anderson and further in view of Burchell does not disclose or suggest every feature of the utility knife of claim 2.

b. Independent claim 2 meets the conditions for patentability because motivation for the proposed modification of the Tebo disclosure has not been established.

The Examiner has also admitted that Tebo in view of Anderson fail to disclose the gripping portion is angulated out of the two-dimensional plane, but contends that it would have been obvious to one having ordinary skill in the art to have provided Tebo in view of Anderson with the handle, as taught by Burchell in order to incorporate a gripping portion that is angulated out of the two-dimensional plane.

In the present instance, appellants maintain that a person of ordinary skill in the art would indubitably recognize that it would be impossible to modify the body 12 of the Tebo utility knife to include a gripping portion that is angulated out of the two-dimensional plane. Modification of the Tebo utility knife in such a manner would clearly render it inoperative for its intended purpose, since the carriage 14 of Tebo would not be permitted to slide along the longitudinal axis to allow the first blade to extend from the first opening and the second blade carried on the carriage to extend from the second opening. That is, the V-shape bend of the body would clearly prevent

the carriage from sliding along a single longitudinal axis in order to allow blades to be used at either end of the utility knife defined by the single longitudinal axis. The Examiner has therefore not pointed to any reasonable motivation for changing the longitudinal body of the Tebo utility knife to have a V-shape such that the gripping portion is angulated away from and out of the two-dimensional plane defined by the knife blade, apart from hindsight afforded by the present application. In the present instance, no basis is established for any Tebo utility knife to be other than a body having a longitudinal axis, defined by a single two-dimensional plane, with openings at either end of the axis. An obviousness determination is thus precluded under *In re Gordon*, 733 F.2d 900, 902, 221 USPQ 1125, 1127 (Fed. Cir. 1984).

Appellants thus maintain that the use of a two-piece V-shaped handle wherein the gripping portion is angulated away from and out of the two-dimensional plane defined by the knife blade provides a technical function on which patentability may be predicated, and which would be unexpected and surprising in the absence of applicant's own disclosure.

Appellants respectfully submit that the present utility knife does not merely represent a different arrangement of structural features of the Tebo utility knife as modified by Anderson and Burchell that nevertheless perform the same function. In *KSR v. Teleflex*, 127 S. Ct. 1727, 1741; 167 L. Ed. 2d 705; 2007 U.S. LEXIS 4745; 75 U.S.L.W. 4289; 82 U.S.P.Q.2D (BNA) 1385; (S. Ct. 2007), the Supreme Court focused obviousness inquiry on whether an "improvement is more than the predictable use of prior art elements according to their established functions" (citing *Anderson's-Black*

Rock, Inc. v. Pavement Salvage Co., 396 U.S. 57, 60-62; 90 S. Ct. 305; 24 L. Ed. 258 (S. Ct. 1969) and *Sakraida v. AG Pro, Inc.*, 425 U.S. 273, 282; 96 S. Ct. 1532; 47 L. Ed. 2d 784 (S. Ct. 1976) (emphases added). An obviousness determination is thus precluded.

The Federal Circuit has consistently held that obviousness cannot be predicated merely on finding the recited elements in a single references or a combination of references. *Symbol Technologies, Inc. v. Opticon, Inc.*, 935 F.2d 1569, 1576, 19 USPQ2d 1241, (Fed. Cir. 1991) ["We do not 'pick and choose among the individual elements of assorted prior art references to recreate the claimed invention,' but rather, we look for 'some teaching or suggestion in the reference to support their use in the particular claimed combination.'"], quoting *Smithkline Diagnostics, Inc. v. Helena Laboratories Corp.*, 859 F.2d 878,887, 8 USPQ2d 1468, 1475 (Fed. Cir. 1988)].

Applicant respectfully maintains that the Examiner has not adduced any evidence, whether in Tebo itself or Anderson or Burchell or elsewhere, that establishes motivation for a skilled artisan to make the particular combination of elements, configured in the manner delineated by the present claims and performing even similar functions, including claim 2. It is thus submitted that the motivation proposed by the Examiner is improper as being a hindsight reconstruction under the test of *In re Rouffet*, 149 F.3d 1350, 1357, 47 USPQ 2d 1453, 1457 (Fed. Cir. 1998):

" . . . 'virtually all [inventions] are combinations of old elements.' *Environmental Designs, Ltd. v. Union Oil Co.*, 713 F.2d 693, 698, 218 USPQ 865, 870 (Fed. Cir. 1983); *see also Richdel, Inc. v. Sunspool Corp.*, 714 F.2d 1573, 1579-80, 219 USPQ 8, 12 (Fed. Cir. 1983) ('Most, if not all, inventions are combinations and mostly of old elements.'). Therefore an examiner may often find every element of a claimed invention in the prior art. If identification of each claimed element in the prior art were sufficient to

negate patentability, very few patents would ever issue. Furthermore, rejecting patents solely by finding prior art corollaries for the claimed elements would permit an examiner to use the claimed invention itself as a blueprint for piecing together elements in the prior art to defeat the patentability of the claimed invention. Such an approach would be 'an illogical and inappropriate process by which to determine patentability.'" *Sensonics, Inc. v. Aerosonic Corp.*, 81 F.3d 1566, 1570, 38 USPQ 2d 1551, 1554 (Fed. Cir. 1996).

The court has articulated a similar warning in *In re Kotzab*, 55 USPQ 2d 1313, 1318 (Fed. Cir. 2000):

"Further, a rejection cannot be predicated on the mere identification in [the reference] of individual components of claimed limitations. Rather, particular findings must be made as to the reason the skilled artisan, with no knowledge of the claimed invention, would have selected these components for combination in the manner claimed."

It is respectfully submitted that the Examiner has not provided any motivation to reconstruct the Tebo utility knife so that it could carry out the function of allowing glaziers and SHEET ROCK (TM) dry wall works to work in tight corners in the configuration delineated by claim 2, apart from the hindsight of the present specification and claims. The need for such a substantial reconstruction is submitted to negate any finding of obviousness. *In re Ratti*, 270 F2d 810, 123 USPQ 349 (C.C.P.A. 1959).

Appellants have discovered that having the gripping portion be angulated with respect to the blade such that the gripping portion is angulated away from and out of the two-dimensional plane defined by the flat surface of the blade produces a unique utility knife construction which, advantageously, provides easy and safe access to tight corners while installing window glazing and/or SHEET ROCK (TM) dry wall. Further, appellants have discovered that having a

substantially V-shaped handle, comprising a substantially V-shaped first member and a substantially V-shaped second member, which is devoid of any pivot point provides a more reliable and safer handle that minimizes the risk of injury to its user when applying significant forces thereto. When compared to any utility knife constructed from the prior art, the utility knife called for by appellants' present claims 2, 4, 5, 7, and 10-12 provides enhanced leverage, access, and visibility, and clearly provides a higher margin of safety for users while working in tight environments.

2. Conclusion.

In view of the foregoing remarks, it is submitted that present claim 2 patentably defines over Tebo in view of Anderson and further in view of Burchell. Accordingly, reversal of the rejection of claim 2 under 35 USC §103(a) over Tebo in view of Anderson and further in view of Burchell is respectfully requested.

(VIII) Conclusion

In light of the foregoing remarks, it is respectfully submitted that claims 2, 4, 5, 7, and 10-12 meet the conditions for patentability, and should not be subject to rejection under 35 U.S.C. §101 as claiming the same invention as that of claims 2, 4, 5, 7, and 10-12 of copending Application No. 11/352,728.

It is further submitted that the utility knife of claim 2 (and claims 4, 5, 7, and 10-12 dependent thereon) is not disclosed or suggested by any combination of the art references applied, and thus meets the conditions for patentability required by 35 U.S.C. § 103(a).

Accordingly, reversal of the rejection of claims 2, 4, 5, 7, and 10-12 under 35 USC §101, and claim 2 (and claims 4, 5, 7, and 10-12 dependent thereon) under 35 USC §103(a), and allowance of the present application, are earnestly solicited.

Respectfully submitted,

Noel C. Cobb et al.

By _____

Ernest D. Buff
(His Attorney)
Reg. No. 25,833
(908) 901-0220
(908) 901-0330 (facsimile)

(IX) Claims Appendix — Claims On Appeal

1. (cancelled)

2. A utility knife for glaziers and SHEET ROCK (TM) dry wall users, comprising,

- a. a reversible, detachable blade having a flat surface that defines a two-dimensional plane in space, said blade having a sharp edge and a plurality of anchoring holes;
- b. a substantially V-shaped handle for supporting the blade, said handle comprising a substantially V-shaped first member and a substantially V-shaped second member, wherein said first member is removably attached to said second member in order to create said substantially V-shaped handle, wherein one leg of the V-shape is a gripping portion and the other leg of the V-shape is a blade supporting portion, and said gripping portion is angulated with respect to said blade such that said gripping portion is angulated away from and out of said two-dimensional plane;
- c. channel means disposed within said blade supporting portion of said handle for containing and supporting said blade;
- d. locating means disposed within said channel means for capturing said blade;
- e. clamping means for clamping said first and second members and supporting said knife blade; and
- f. a cavity for holding extra knife blade elements;

wherein a user may expose a fresh edge of said blade by either replacing said blade with a new blade from said cavity or by rotating said blade by 180 degrees to change handedness of said utility knife.

Applicant : Noel C. Cobb et al.
Serial No. : 10/822,240
Filed : April 9, 2004
Page : 29

Attorney Docket No.: 0075-1

3. (cancelled)
4. A utility knife as recited by claim 2 wherein said angulation ranges from about 100 degrees to about 170 degrees.
5. A utility knife as recited by claim 2 wherein said angulation ranges from about 135 degrees to about 150 degrees.
6. (cancelled)
7. A utility knife as recited in claim 2 wherein said locating means is attached to said second member.
8. (cancelled)
9. (cancelled)
10. A utility knife as recited by claim 2 wherein said clamping means comprises at least one bolt.
11. A utility knife as recited by claim 10, wherein said at least one bolt is threaded through said first member.
12. A utility knife as recited by claim 10, wherein said at least one bolt is slidably fitted to said second member.

Applicant : Noel C. Cobb et al.
Serial No. : 10/822,240
Filed : April 9, 2004
Page : 30

Attorney Docket No.: 0075-1

(X) Evidence Appendix

Not applicable.

Applicant : Noel C. Cobb et al.
Serial No. : 10/822,240
Filed : April 9, 2004
Page : 31

Attorney Docket No.: 0075-1

(XI) Related Proceedings Appendix

Not applicable.